

Rolloscope II®

Motorized General Purpose Filmviewer

Accelerate throughput with Rolloscope II®

For over four decades, Rolloscope II has helped thousands of sites drive productivity.

Get in the fast lane, today.

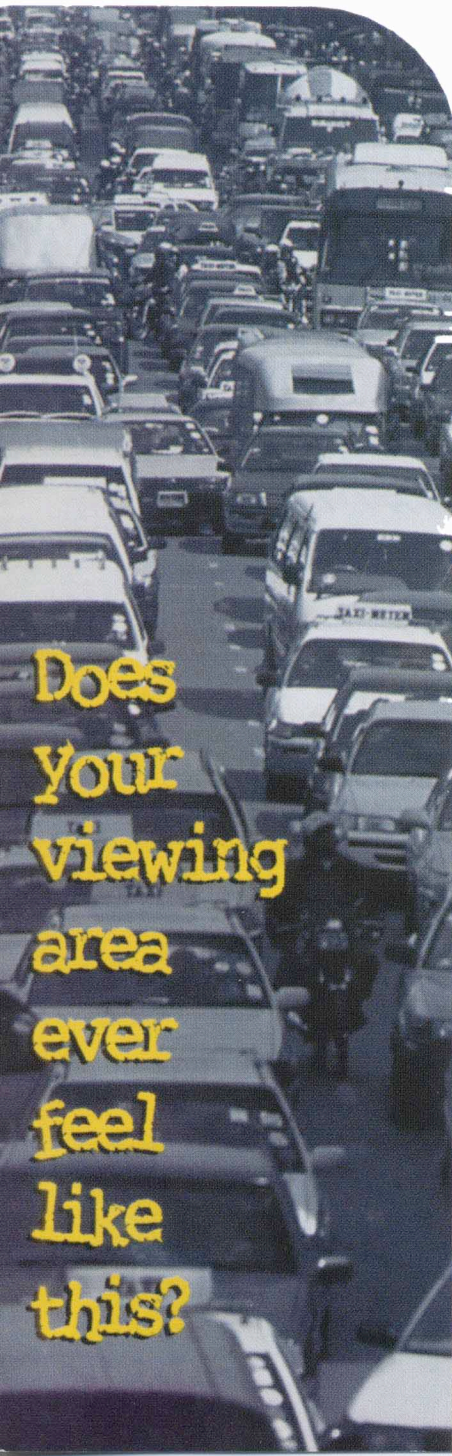

Does
your
viewing
area
ever
feel
like
this?

View Films Within Minutes:

- ▶ Delivered directly to designated area
- ▶ Comes blanket-wrapped; no messy packing materials
- ▶ Moves easily on large wheels; no dollies needed
- ▶ Fits through a standard door
- ▶ Requires only one 20AMP outlet to operate

Discover Efficient Design:

- ▶ Holds 400 14" x 17" films; more with smaller films
- ▶ No strings to hold films:
 - Unobstructed viewing
 - Easy to load and unload
- ▶ Adjustable light output from 875 to 3,500 nit
- ▶ Eight individually controlled light frames
- ▶ Vertical scrolling; view sitting or standing
- ▶ Slanted viewing area minimizes back strain
- ▶ Optional frame selector accesses any of 50 panels (100 rows)

And Reliability For The Road Ahead:

- ▶ Film belt - normal life expectancy a minimum of 10 years
- ▶ "Off the shelf" parts for easy maintenance
- ▶ Nationwide technical support

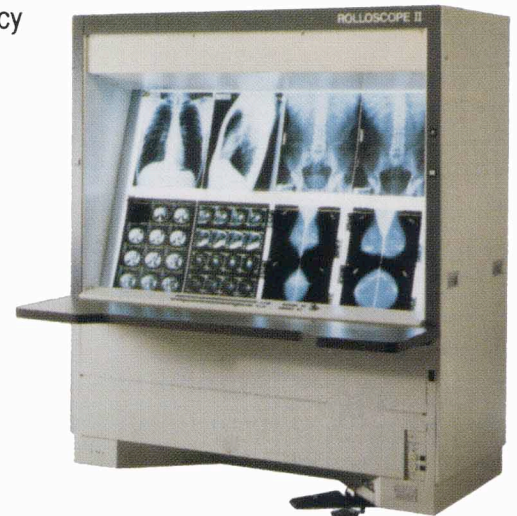

Rolloscope II®

Motorized General Purpose Filmviewer

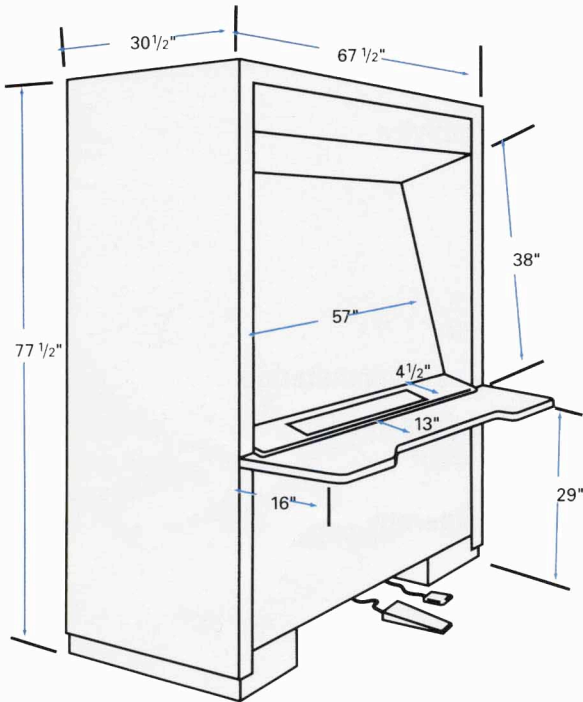

Underwriters Laboratories Classified
Made in the U.S.A.
CL Approved

General Specifications:

Floor Space:	68" x 32"
Film Capacity:	400 14" x 17" films, on 50 separate panels
Viewing Area:	38" x 57" (965 x 1450 mm) with eight individual viewing areas in a "four-over-four" format
Film Transport Belt:	Motor driven, up or down
Film Transport Speed:	1 film row/sec.
Light Output:*	875-3500 nit (candela/m ²)
Heat Output:	Max: 2200 BTU/hour
Weight:	Net: 1000lbs. (454 kg)

Standard Version - Catalog#: 125-004

ROLLO 2 Motorized High-Capacity Filmviewer
Completely assembled, including scrolling footswitch, hot light footswitch and fluorescent lamps. Outlets for owner's hot light and recorder. 120V, 60Hz.

Power Requirements

Line Voltage:	100 - 130 VAC
Frequency:	60Hz
Fuse:	20A

Optional:

Auto Frame Selector-Factory Installed-Catalog#:125-004A

LED readout identifies desired frame position; convenient thumbwheel control easily dials in desired frame; up/down push buttons for single row scroll.

Hot Light with Adjustable Iris - Catalog#: sp-2

Allows a 1/4" to 4" diameter field of light. Excludes extraneous light to easily pinpoint area of concern on the film. Foot operated dimmer provides variable light intensity.

Conversion Table

Rounded to nearest 1/16"

INCHES	77 1/2	67 1/2	57	38	30 1/2	29	16	13	4 1/2
MM	1970	1715	1450	965	775	736 1/2	406	330	114



T. (800)232-2948
F. (800)625-1381
EMAIL: info@broadwest.com