



KONICA MINOLTA

# SRX-201A

*Mid-Volume Processor*

## *Ideally suited for all mid-volume applications*

*Three processing speeds at the touch of a button.*

*Excellent choice for dedicated active mammography applications.*

*Active circulation system for more consistent film processing.*

### **Easy Operation and Maintenance**

#### **Automatic Chemical Supply**

The SRX-201A automatically (or by operator control) replaces developer and fixer solution minimizing the risk of chemical splash and staining.

#### **Standby Function**

In addition to the normal jog cycle standby function (0–30 minutes), a night standby function is incorporated for emergency situations at facilities such as hospitals which operate 24 hours a day.

#### **Self Rinsing Crossover Rack**

The SRX-201A is designed with a self rinsing developer-fixer cross-over rack. The rollers in the cross-over rack are continually washed, thus minimizing regular cleaning and chemical carry out.

### **Technology in Design**

The processor tank is constructed from materials to resist the corrosive effects of the processing chemicals. The one-piece design of the evaporation barrier and transport rack help to minimize chemical exhaust.

### **Compact Design Combined with Simple Operation**

The control panel has a separate indicator for chemical temperature and system error monitoring, enabling simple operation. All system indicators and buttons are simply designed, providing easy and reliable access to the information. The SRX-201A's compact design requires just 0.429 square meters (approx. 7 square feet) of space, excluding feed tray, to install.

### **Safety function**

The SRX-201A incorporates a number of safety functions such as the safety interlock mechanism. This is designed to stop the processor when the top cover is opened. In addition, the SRX-201A has a darkroom function mode to enable you to turn off all indicator lights when the unit is installed completely within a darkroom.

### **Multiple Speed for Maximum Versatility**

The SRX-201A offers processing speeds of 60, 90, and 170 seconds. This will allow you to choose the optimum cycle speed to match your processing needs whether it be orthochromatic, mammographic, or any other conventional imaging film. The transport system accepts film sizes from a minimum 8" x 10" up to and including 14" x 17" crosswise, or two, side-by-side 8" x 10" films.

### **Bilateral Circulation for Stable Processing**

One-piece construction of the processing rack assemblies enables the developer and fixer solutions to be properly circulated.



The essentials of imaging

### Outer Dimensions of SRX-201A

Dimensions: 650 x 660 (997 incl. feed tray) x 1100mm  
(W x D x H) 25.6 x 26.0 (39.3 incl. feed tray) x 43.3 inch

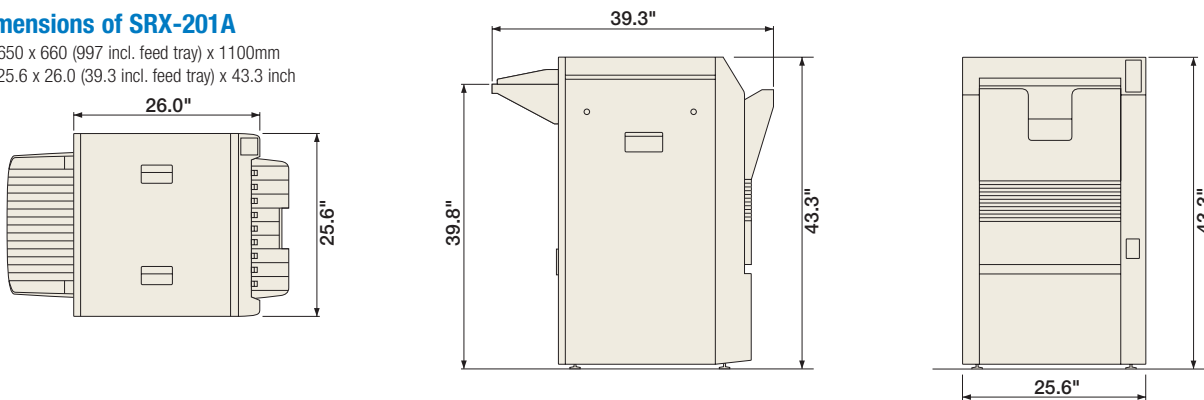

## SRX-201A Specifications

<b>Film Transport Method</b>	Continuous roller transport		
<b>Film Type and Sizes</b>	Sheet film, 10x10cm–35x43cm sizes (14"x17")		
<b>Processing Capacity</b>	Cycle/Size	10x12inch or 24x30cm	14x17inch (35x43cm)
	60 sec.	200	160
	90 sec.	140	115
	170 sec.	80	60 (sheets/hr)
<b>Process Cycle Switching</b>	Easy operation via the control panel.		
<b>Processing Solution Volumes</b>	DEV tank	: 7.8 liters (2.06 gallons)	
	FIX tank	: 5.6 liters (1.48 gallons)	
	WASH tank	: 4.4 liters (1.16 gallons)	
<b>Drying System</b>	Forced hot air circulation method		
<b>Circulation System</b>	Piping installed in the DEV and FIX racks.		
<b>Temperature Control</b>	Processing solution temperature; Controlled by the temperature control tank, with the thermistor monitoring, with the heater heating and with the wash water cooling. Drying temperature; Controlled automatically according to a fixed temperature setting.		
<b>Replenishing System</b>	Replenishing volume for the film sheet is calculated with exchanging 10x12 inch film.		
<b>Wash Water</b>	Ordinary tap water 41–86°F (5–30°C) Water pressure 147–686kPa (1.5–7kgf/cm <sup>2</sup> ) (21–99.56psi)		
<b>Water Supply</b>	3 liters (0.8 gallon) /min. The flow control valve is equipped.		
<b>Standby Functions</b>	Jog cycle standby and night standby		
<b>Power Source</b>	AC 208/220/230/240V, single phase, 20A, 60 Hz.		
<b>Weight</b>	242lb (308lb with processing solutions) 110kg (140kg with processing solutions)		
<b>Certification</b>	Conforms to UL, C-UL, FDA		
<b>Applied Standard</b>	FCC		
<b>Heat Generation</b>	Approx. 3,780kJ/hr max. 3,500 BTU		
<b>Noise Level</b>	Approx. 60dB (A) max.		
<b>Operating Condition</b>	59–86°F (15–30°C), 30–75%RH (no condensation)		
<b>Electromagnetic Compatibility</b>	Compliance with EN60601-1-2		
<b>Safety Standard</b>	Compliance with IEC60601-1-1		
<b>Accessories</b>	Polyethylene beaker, Graduated cylinder, Funnel, Installation kit, Spare parts kit, and Operation manual.		
<b>Optional Equipment</b>	Light shield panel Automatic drainage valve unit Automatic cooling valve unit		

\*The above specifications are subject to change without prior notice.

## Konica Minolta Technical and Professional Installation and Service

As a world-class organization, Konica Minolta Medical Imaging is dedicated to providing our customers with quality installation, technical support and service through a nationwide network of full line dealers. Our professional service experts are available locally to ensure that your equipment and medical imaging business runs at peak performance.

Our Authorized Full Line Dealers also provide Konica Minolta Medical Imaging film, as well as, related supplies and accessories to support each and every customer's needs.



KONICA MINOLTA

Distributed by  
CAN-med Healthcare  
East 1 866 277 3577  
West 1 800 661 5671

www.canmedhealthcare.com

KONICA MINOLTA MEDICAL IMAGING USA, INC.  
411 NEWARK POMPTON TURNPIKE  
WAYNE, NJ 07470  
TEL: (973) 633-1500 FAX: (973) 523-7408  
WEBSITE: medical.konicaminolta.us